

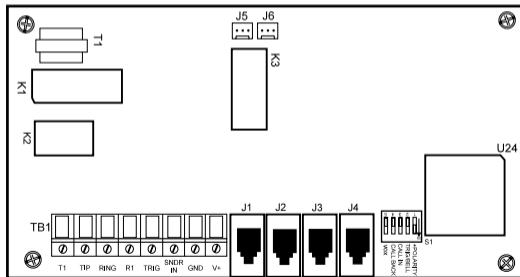

# VALIDATOR™

## Audio Verification System Installation Instructions



---

# *Table of Contents*

Introduction .....	3	Speaker/Microphone/Sounder Units .....	12
Operating Modes .....	3	Relay Outputs .....	12
Auto Mode .....	4	Switch Settings .....	16
Call Back Mode .....	4	Operator Commands .....	17
Call In Mode .....	5	FCC Notice .....	21
Connecting the CP-100 .....	6	Industry Canada .....	22
Telephone Connections .....	6	Specifications .....	23
Trigger Input .....	6	CP-120 Installation Instructions .....	24
Internal Sounder .....	8	Wiring the CP-120 .....	25
Power .....	8	Zone Description .....	26
Wiring the CP-100 .....	9	Central Station Information .....	27
Additional Connections .....	12		

---

## Introduction

The CP-100 Validator is a two-way audio verification device. Installation is quick and easy, with minimal wiring connections and programming options. The CP-100 is capable of supporting up to four CP-120 Speaker/Microphone/Sounder units, allowing the central station to conduct two-way operations in multiple areas. The CP-100 easily connects to control panels with or without audio verification trigger outputs.

## Operating Modes

The CP-100 provides three separate modes of operation:

**Auto Mode** - Automatically initiates audio verification session following alarm reporting;

**Call Back Mode** - Allows Central Station operator to call back to the CP-100 Validator to initiate session after the alarm is reported and CP-100 is triggered;

**Call In Mode** - Stand alone operation, allows activation of an audio verification session independent of panel status.

## **Auto Mode**

The Auto Mode is the basic connection mode for the CP-100 Validator. It is selected when switch S1-4 is set to OFF. This mode uses the control panel's "Listen-In" trigger output, or the Bell output (if no separate output trigger is available) to activate the Audio Verification session. The CP-100 is enabled by connecting the panel's output to the "TRIG" terminal on the printed circuit board (PCB). The "TRIG" input can accept either a positive going or a negative going trigger. Switch S1-1 determines the input trigger polarity for the CP-100. (See pages 6 and 16 for additional information.)

Once a trigger condition exists, the module will seize the line and send a tri-tone every 2 seconds for 60 seconds. The central station operator must depress the [\*] key within the 60-second time window using a telephone that generates DTMF tones to initiate the audio verification session. When the CP-100 recognizes the correct DTMF tone, it will generate a low confirmation tone to alert the operator that the CP-100 is now active.

## **Call Back Mode**

The Call Back mode is enabled by setting S1-4 to ON. The two-way audio verification session is activated by the control panel as stated above. After the digital communicator has completed its transmission, it will receive the kiss-off tone from the receiver and hang up. The operator then has 2.5 minutes to call the premises back. The CP-100 will answer on the first ring, seize the phone line, and the Central Station operator must follow the procedure outlined previously with the Auto Mode to initiate and confirm the start of the audio verification session.

## Call In Mode

The Call In mode, selected via S1-3, is basically used as a stand-alone operating mode, allowing activation of an audio verification session independent of panel status. (Refer to page 16, Table 2 for switch settings.) When enabled, the module relies on the operator to make the inbound calls to activate the unit.

To initiate an audio verification session, the operator must dial the number, listen for one full ring and one partial ring (the partial ring may precede or follow the full ring), then hang up. After waiting for 10 to 20 seconds, the operator redials the number. The second call to the unit will be answered by the CP-100 on the first ring. This procedure is used to bypass devices such as answering machines, faxes and modems that may be connected to the same phone line. After the CP-100 answers, it will seize the phone line and send a tri-tone every 2 seconds for 60 seconds. If the control panel that is connected to the same telephone line has remote programming capability, there will be a delay in receiving the tri-tones while the panel seizes the line looking for an "ack" signal from the central station. Failing to receive the signal, the panel will disconnect and the operator will hear the tri-tones. The operator must depress the [\*] key within the 60-second window using a DTMF telephone to initiate the audio verification session. When the module recognizes the correct DTMF tone, a low confirmation tone will be generated to let the operator know that the module is now active.

**NOTE: This option may compromise the privacy of the user and should ONLY be activated with the expressed written approval of the user.**

## Connecting the CP-100

When connecting the CP-100, the following installation guidelines should be followed:

All connections to the main PCB and the speaker/microphone units must be made with power removed. The CP-100 Terminals are shown in Figure 1. See pages 9, 10, 11, 14 and 15 for complete wiring diagrams.

### Telephone Connections (TIP, RING, T1 and R1)

Connect the control panel T1 and R1 terminals/outputs to the terminals marked **TIP** and **RING** on the CP-100. Then connect the CP-100's **T1** and **R1** to the house phones. The control panel **MUST ALWAYS** have the priority to seize the telephone line from the CP-100.

### Trigger Input [TRIG]

If the control panel provides a trigger output, connect it to the CP-100's **TRIG** terminal. Set switch S1 to the proper polarity; then set switch S2 to "OFF."

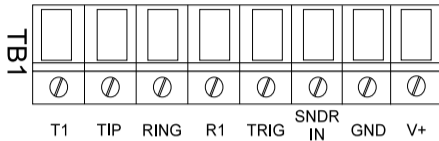

**Figure 1**  
**CP-100 Terminal Connections**

## Trigger Input [TRIG] (continued)

The CP-100 trigger requires an input voltage of 2V to 50V. If the trigger output from the control panel is a normally open collector and only able to sink current to ground, then a pull-up resistor (22K) must be added from V+ or a 5 Volt supply to the trigger input.

If the control panel does not have a trigger output, connect the Bell Output to the **TRIG** terminal on the CP-100. Set switch S1 to the proper polarity, and then set switch S2 to "ON." Use the installation instructions supplied with the control panel to determine the system's output capabilities. (In most cases, when using the bell output as a trigger, switch S1 should be set "ON.")

**If the control panel's Bell output is used as a trigger, then no audio verification is available during Hold-Up, Silent Panic, or Ambush alarms. For these conditions, a separate trigger must be provided, i.e., a C&K 2300-DVR.**

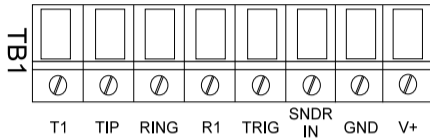

**Figure 2**  
**CP-100 Terminal Connections**

## Trigger Input [TRIG] (continued)

The Audio Verification session can be interrupted when the control panel needs to send additional signals. To minimize this problem, program each zone to suppress any additional signals that may be generated from this zone (i.e., swinger shunt, swinger shutdown, or suppress restoral reports).

## Internal Sounder (SNDR IN)

Each CP-120 is a Speaker/Microphone/Sounder unit. To use the sounder (internal siren), connect the control panel Bell + terminal to the **SNDR IN** terminal of the CP-100. This provides sounder power, eliminating the need for external siren drivers. The control panel's Bell output terminal must be capable of supplying 10 - 14 VDC at 200 mA if one or two CP-120's are connected. A total of 400 mA is required if three or four CP-120's are connected. The CP-120's Internal Sounder is automatically cut-off during an audio verification session.

## Power (V+ and GND)

Connect power from the AUX Power terminals on the control panel to the **V+** and **GND** terminals on the CP-100, using 18 - 22 AWG wire. The control panel must be capable of supplying 10 - 14 VDC at 160 mA. (Refer to the Internal Sounder section above for CP-120 power requirements.)

**NOTE:** Refer to page 16 for trigger polarity information.



## Wiring the CP-100

Figures 3a, 3b, and 3c show different wiring configurations for the CP-100. Figures 3d and 3e show use of relay outputs. (See pages 9 to 11, 14 and 15.)

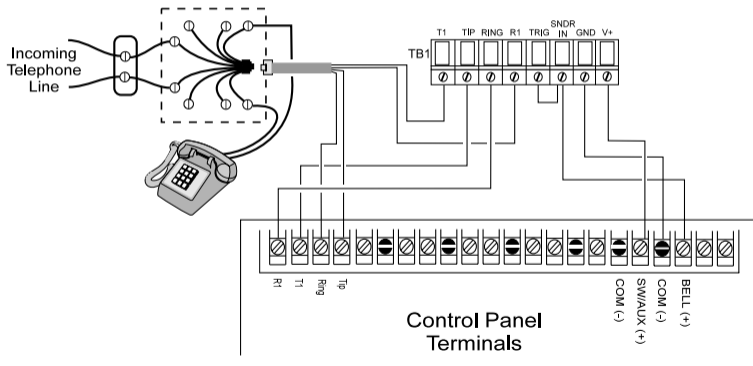

**Figure 3a**  
**CP-100 Control Panel without**  
**a Panel Trigger Output, and**  
**Telephone Connections**

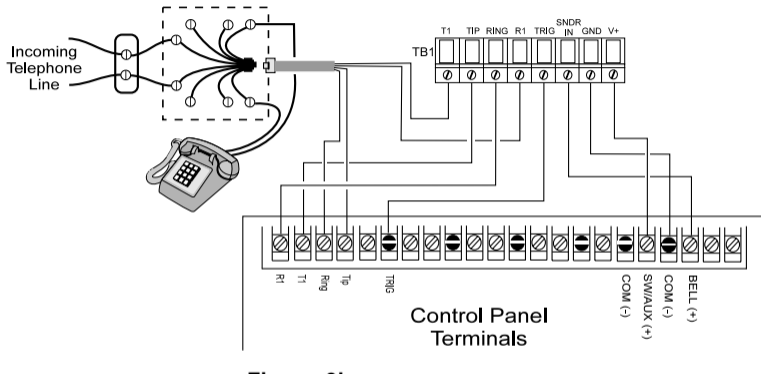
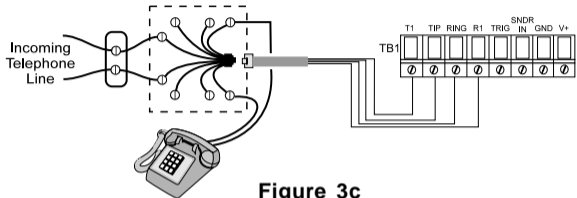

**Figure 3b**  
**CP-100 Control Panel with a Panel Trigger**  
**Output, and Telephone Connections**

## Wiring the CP-100 (continued)

Figure 3c shows the CP-100 connected to a telephone RJ31X without a control panel.

For uninterrupted operation, power must be supplied with battery back-up. At a minimum, the power must be 12 V, and 0.5 amp.



**Figure 3c**  
**CP-100 Telephone Connections**

---

## Additional Connections

### Speaker/Microphone/Sounder Units (J1 - J4)

Up to four CP-120 Speaker/Microphone/Sounder units can be connected to the CP-100 at one time. Connections are made via a standard 6-way modular telco cable. Plug one end into the CP-120 Speaker/Microphone/Sounder unit and the other into the jack labeled J1 through J4 on the CP-100. **Always connect the units in consecutive order from J1 to J4 without skipping positions.**

**NOTE: Bell output must be capable of supplying 10 - 14 VDC @ 200 mA for one or two CP-120's used. If three or four CP-120's are used, 400 mA is required.**

### Relay Outputs (J5 and J6)

Connectors J5 and J6 are two Form C contacts that follow the operation of the Audio Verification session. When the operator initiates a session, the relay changes state. When a session is properly terminated or times out, the relay returns to its original state. During a session, the common (C) disconnects from Normally Closed (NC) and connects to Normally Open (NO) on both J5 and J6. These contacts are rated for 5 Amps @ 120 VAC/24 VDC. Connection is via plug-in connectors using 5" flying leads, supplied with the system.

## Relay Outputs (J5 and J6) (continued)

Table 1 shows the connections for the relay outputs from J5 and J6. These connections may be used to temporarily turn off electromechanical devices that will generate noise in the listening area(s). Other examples of relay use are: turn outside sirens on/off, turn lights on/off, etc.

Figure 3d illustrates the use of J5 as an external bell cutoff device.

**Table 1**  
**J5 & J6 Connections**

Pin #	3	2	1
Term.	NC	NO	C

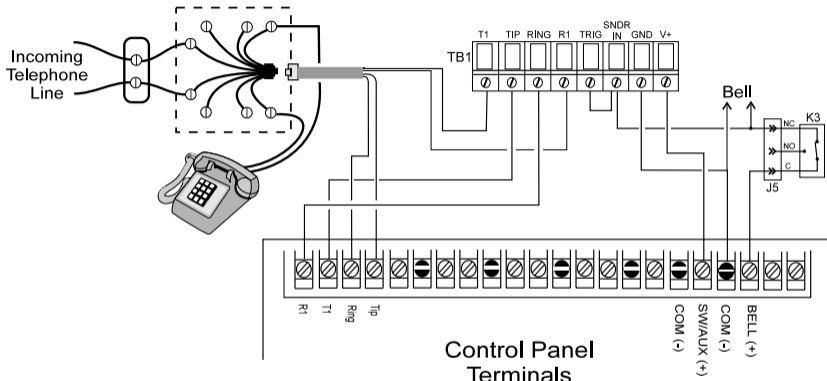

**Figure 3d**  
**Using K3 as an alarm cut-off switch, bell is disconnected during Audio Verification Session**

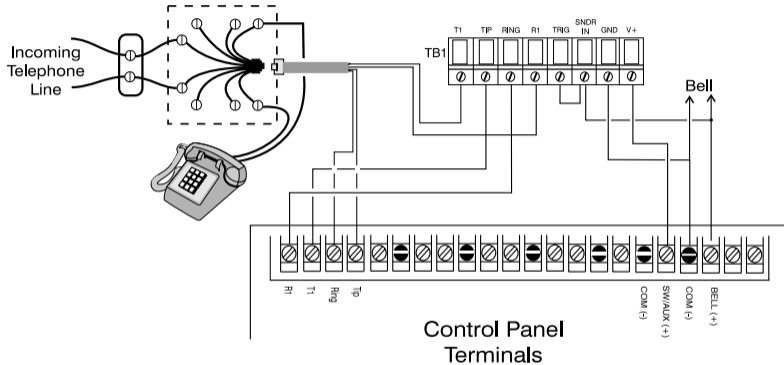

**Figure 3e**  
**Bell operates during Audio Verification Session**

## Switch Settings

Position	Function	ON	OFF
1	Trigger Polarity	Positive-Going Trigger	Negative-Going Trigger
2	TRIG/BELL Input	Bell Input Enabled	Trigger Input Enabled
3	Call In Mode	Call In Mode Enabled	Call In Mode Disabled
4	Call Back Mode	Call Back Mode Enabled	Auto Mode Enabled
5	VOX Mode	VOX Enabled	Manual Listen/Talk (No VOX)

**Table 2 Switch S1 Settings**

If the Call Back mode is enabled, Auto mode is disabled. If Call In mode is enabled, no effect on Auto or Call Back modes is noted.

**NOTE:** Call In Mode may compromise privacy of the user, and should **ONLY** be activated with the expressed written consent of the user.



## Operator Commands: Special Keys (All DTMF tones will restart the 5-minute timer.) **Confirm Tone**

DTMF Key	Function	
[*]	Initiates the audio verification session. Once the session has been initiated, this key is used to indicate a change to multiple levels of operation commands. (i.e., Base Level, First Level, etc.)	L
<b>NOTE:</b>	<b>Central Station operator will not hear the tri-tones until the panel releases (unseizes) the phone line.</b>	
[#]	Only used to cancel previous DTMF key commands.	None

### Base Level Operation

[1]	Activates "Talk Only" mode. In this mode, all microphones are disabled.	H
[2]	Activates "VOX" (Voice Activated) mode. This key also allows the operator to toggle the gain of the microphone between normal or high.	HHHL

**NOTE:** When "VOX" or "Listen Only" is in the High gain mode, the CP-100 will automatically cycle High gain: 17 seconds, Normal gain: 3 seconds. This will permit the central station operator to input key generated DTMF tones to change operating parameters of the Validator system. This will eliminate total blockage of DTMF tones by background noise in High gain mode.

**Confirmation Tones:**  
H = 1800 Hz; L = 800 Hz.

[3] Activates "Listen Only" mode. In this mode, all selected microphones will be activated, and all the speaker units will be disabled. After the key is depressed and the module switches over to the "Listen Only" mode, it will come up in the gain (volume) used in the previous mode. This key also allows the operator to toggle the microphone gain between normal and high.

HHHL

**NOTE:** When "VOX" or "Listen Only" is in the High gain mode, the CP-100 will automatically cycle High gain: 17 seconds, Normal gain: 3 seconds. This will permit the central station operator to input key generated DTMF tones to change operating parameters of the Validator system. This will eliminate total blockage of DTMF tones by background noise in High gain mode.

[7] Initial audio verification session is 5 minutes. Depressing the [7] key will extend the time by an additional 5 minutes. All other DTMF tones, except 88 and 99, will also restart the five minute timeframe.

H

**NOTE:** If the audio verification session is terminated without using [88] or [99], the unit will remain on-line until it times out (5 minutes after last DTMF tone) and the telephone system error messages/tones will be broadcast over the CP-120 speakers.

[88] Terminate the audio verification session and enter the Call Back Mode. The operator has 4 minutes to Call Back to the CP-100. If S1-4 (Call Back Switch) is OFF, this command will *temporarily* override the switch setting. None

**NOTE:** When terminating an audio verification session with "88", and attempting to reconnect with the CP-100, some panels may send an "ack" tone. Simply hang-up and redial. The CP-100 will still answer the call.

[99] Terminate the audio verification session and return to the idle mode. None

**NOTE:** If the audio verification session is terminated without using [88] or [99], the unit will remain on-line until it times out (5 minutes after last DTMF tone) and the telephone system error messages/tones will be broadcast over the CP-120 speakers.

## First Level Operation

[*1n]	Toggle microphone on/off. (n = microphone number 1, 2, 3, or 4)	HHH (ON) H (OFF) HHH
[*18]	Turn all microphones ON.	HHH
[*19]	Turn all microphones OFF.	H

**NOTE:** If microphones are turned off using [\*19], they will remain OFF when returning to Base Level operation. To reactivate, use [\*18] or [\*1n] prior to using the [2] or [3] Base Level Functions.

**NOTE:** Maximum time between keys strokes for multi-key operation is 5 seconds.

## Other Audible Tones

Twenty seconds before the end of the five minute interval, the central station operator will hear one high tone.	H
--	---

Ten seconds before the end of the five minute interval, the central station operator will hear one low tone.	L
--	---

## FCC Notice

**WARNING:** This device is intended to be installed by a professional alarm installer. The user shall be cautioned that changes or modifications not expressly approved by C&K SYSTEMS could void the user's authority to operate the equipment.

This equipment has been tested and found to comply with the limits for a Class B digital devices, pursuant to Part 15 of the FCC Rules. These limits are designed to provide reasonable protection against harmful interference in a residential installation. This equipment generates, uses, and can radiate radio frequency energy, and if not installed and used in accordance with the instructions, may cause harmful interference to radio communications. However, there is no guarantee that interference will not occur in a particular installation. If this equipment does cause harmful interference to radio or television reception, which can be determined by turning the equipment off and on, the user is encouraged to try to correct the interference by one or more of the following measures: (1) Reorient the radio/television antenna. (2) Connect the AC transformer to a different outlet so that the control panel and radio/television are on different branch circuits. (3) Relocate the control panel with respect to the radio/television. (4) Consult the dealer or an experienced radio/television technician for help.

In accordance with Part 68 of the FCC Rules, this device must not be used on party lines or coin operated phone lines.

If you experience trouble with the telephone lines, disconnect the panel and the CP-100 Validator from the telephone lines to determine the source of the trouble. If it is determined that the CP-100 Validator is malfunctioning, disconnect from the system until the malfunction has been corrected. Repairs to this equipment should be made by an authorized agent of C&K Systems. Contact your local alarm installation company for service.

## Industry Canada

**NOTICE:** The Canadian Department of Communications label identifies certified equipment. This certification means that the equipment meets certain telecommunications network protective, operational and safety requirements. The Department does not guarantee the equipment will operate to the user's satisfaction.

Before installing this equipment, users should ensure that it is permissible to be connected to the facilities of the local telecommunications company. The equipment must also be installed using an acceptable method of connection. In some cases, the company's inside wiring associated with a single line individual service may be extended by means of a certified connector assembly (telephone extension cord). The customer should be aware that compliance with the above conditions may not prevent degradation of service in some situations.

Any repairs or alterations made by the user to this equipment, or equipment malfunctions, may give the telecommunications company cause to request the user to disconnect the equipment. Repairs to certified equipment should be made by an authorized agent of C&K Systems. Contact your local alarm installation company for service.

Users should ensure for their own protection that the electrical ground connections of the power utility, telephone lines and internal metallic water pipe system, if present, are connected together. This precaution may be particularly important in rural areas.

**Caution:** Users should not attempt to make such connections themselves, but should contact the appropriate electric inspection authority, or electrician, as appropriate.

The Load Number (LN) assigned to each terminal device denotes the percentage of the total load to be connected to a telephone loop which is used by the device, to prevent overloading. The termination on a loop may consist of any combination of devices subject only to the requirement that the total of the Load Numbers of all the devices does not exceed 100.

This Class B digital apparatus meets all requirements of the Canadian Interference-Causing Equipment Regulations.

Cet appareil numérique de la classe B respecte toutes les exigences du Règlement sur le matériel brouilleur du Canada.

# Specifications

## CP-100

## CP-120

### ELECTRICAL

Voltage:

10 - 14 VDC

10 - 14 VDC

Current (maximum):

160 mA

100 mA per unit\*

### ENVIRONMENTAL RANGES

Operating Temperature:

15° to 120° F

15° to 120° F

Humidity:

5% to 95% relative humidity,  
non condensing

5% to 95% relative humidity,  
non condensing

### PHYSICAL

Height:

1-5/8"

1-7/8"

Width:

3"

3-3/8"

Length:

6"

4-3/8"

Weight:

6 oz.

1 lb. 8oz.

### OTHER

SPL (Sounder Operation):

N/A

92 dB at 1 meter

Color

N/A

White

\*Note: first two units: 200mA max; second two units: 400 mA max

# CP-120

## Speaker/Microphone/Sounder Installation Instructions Mounting the CP-120

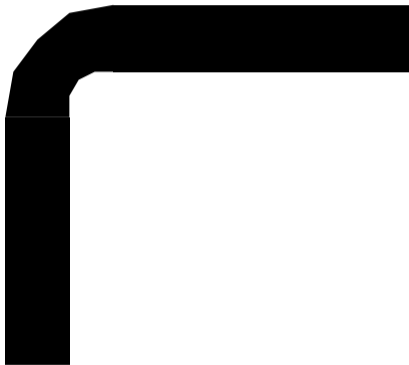

*REAR COVER*

Depress the latch with a screwdriver to separate the two covers.

Secure the rear cover to the wall with the screws provided. If the wall is made of drywall or plaster, drill holes into the wall and install the plastic screw inserts provided; then secure the rear cover to wall.

Insert the wires through the hole in the rear cover.

Align the hooking pins and latch on the rear cover with the front cover. Press firmly. The two covers will lock into place.

Do not mount the CP-120 within 10 feet of HVAC intake or output, or other noisy devices.



## Wiring the CP-120

Pass the 6-wire telco cable through the opening in the rear cover and connect to phone jack J1.

All connections, including power, are made through the telco cable. The CP-120 is supplied with a 25 ft. cable. Cable length should not exceed 150 ft.

*For optimum performance, microphone should be aimed downward, as shown.*

If your application requires a longer cable, use the diagram to the right when making a replacement cable:

Use RJ11  
connector.



**FRONT COVER**

(C&K P/N 0-002-004-01 is two RJ11 connectors with 8" flying leads for splicing to any cable length.)

---

## Zone Description

Use the chart below to indicate the area (zone) covered by each of the CP-120 Speaker/Microphone/Sounder inputs.

Input	Area Covered
J1	
J2	
J3	
J4	

## C&K CP-100 Validator™ Central Station Information

DTMF	DESCRIPTION	CONFIRM TONE <small>L=Low H=High</small>
*	Initiates session.	L
#	Cancels previous command(s).	None
1	Activates Talk-Only mode	H
2	Activates VOX mode/ toggles between normal and high microphone gain	HHHL
3	Activates Listen-Only mode/ toggles between normal and high microphone gain	HHHL
7	Extends session five minutes	H
88	Terminates session, returns to Call Back mode	None
99	Terminates session, returns to idle mode	None
*1n	Turns microphone n on or off (n = 1,2,3,or 4)	HHH (on) / H (off)
*18	Turns all microphones on	HHH
*19	Turns all microphones off	H

cut here

## Central Station Information

Please fill out and give to your central station.

Account #: \_\_\_\_\_

Customer Name: \_\_\_\_\_

Address: \_\_\_\_\_  
\_\_\_\_\_

Telephone #: \_\_\_\_\_

Installing Company: \_\_\_\_\_

Address: \_\_\_\_\_  
\_\_\_\_\_

Telephone #: \_\_\_\_\_

Date of Installation: \_\_\_\_\_

cut here.

P/N 5-051-363-00 Rev B  
Copyright 1996, C&K  
Systems, Inc.  
All Rights Reserved

C&K is a registered trademark of  
C&K Components, Inc.  
Validator is a trademark of C&K  
Systems, Inc.